

Monitoring:

SIMP is based upon a permanent 20 meter vegetation sampling transect randomly placed in a suitable (at least 1 acre) infestation of the target weed and timed counts of the associated biocontrol agent(s). Annual vegetation sampling will allow for characterizing the plant community and the abundance and vigor of target weed. Visual counts of biocontrol agent(s) provide an estimate of biocontrol population level.

Permanent Site Set-up:

To set up the vegetation monitoring transect, you will need:

- 1) a 25 x 50 cm Daubenmire frame made from PVC (preferred) or rebar
- 2) a 20 m tape measure for the transect and plant height
- 3) 10 permanent markers (road whiskers and 16 penny nails – see picture at right)
- 4) a post (stake or piece of rebar) to monument the site (see pictures for examples of field equipment)
- 5) 30-45 minutes at the site during the **last week of July**.

To set up the transect, place the 20 m tape randomly within the infestation. Mark the beginning of the transect with a post. Place permanent markers every 2 m (for a total of 10 markers) beginning at the 2 m mark and ending with the 20 meter mark on the tape measure. Place the Daubenmire frame parallel to the tape on the 50 cm side with the permanent marker in the upper left corner starting at 2m (see pictures). **Refer to the data collection sheet for how to conduct monitoring.** Repeat the frame placement at 2m intervals for a total of 10 measurements (one at each permanent marker).

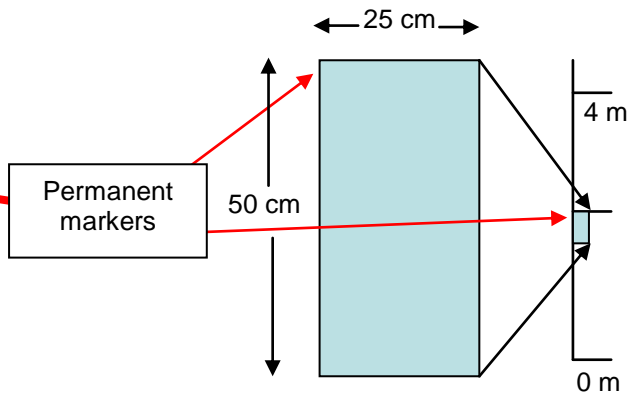
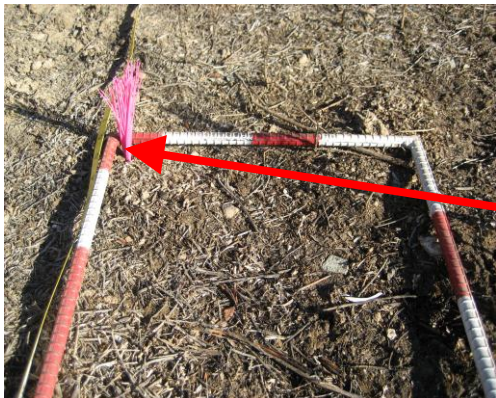
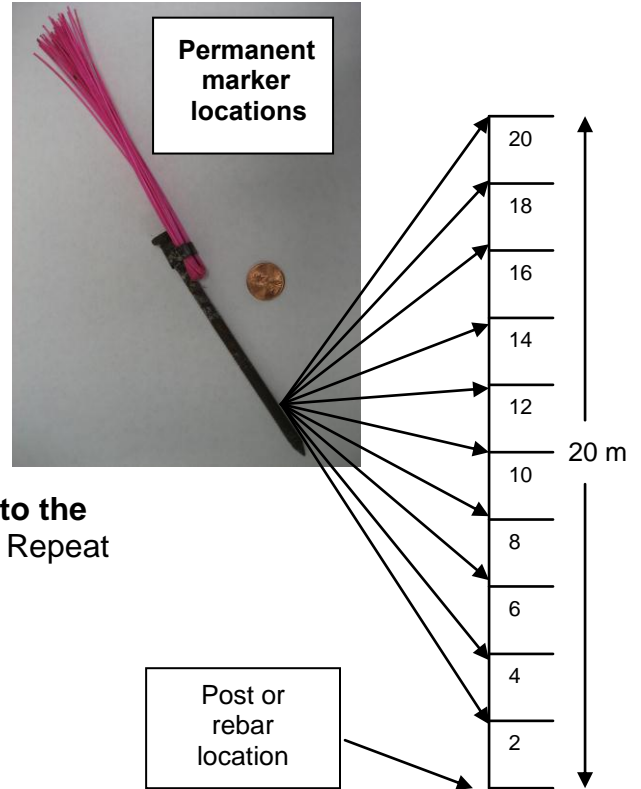

Monitoring biological control agents is an essential component of a successful biological control program. Monitoring data can be used to accurately document the impact of this weed management practice. This monitoring form has been endorsed by the Nez Perce Biocontrol Center, University of Idaho, Forest Health Protection, Bureau of Land Management, and Idaho State Department of Agriculture. The monitoring information from this form will be used to document vegetation cover, target weed density, and biological control agent abundance. When conducted annually, this monitoring data will document changes that occur over time.

Standardized Impact Monitoring Protocol (SIMP) Biological Control Monitoring Form

General Information:

Observer(s):		Date:	Landowner:
Permanent site? Y N	Site name:		Weed:
Biological control agent:		Insect Stage:	
Lat/Long: N ° ' "	W ° ' "	UTM Datum:	UTM E:
		UTM Year :	UTM N:

Weed Infestation:

Size in acres:	Picture taken?	Yes	No	If Y, picture direction:
----------------	----------------	-----	----	--------------------------

Vegetation cover (all in %, rows add to 100%):

Frame	Target weed%	Other weed%	Forb/shrub%	Perennial Grass%	Bare ground%	Litter%	Moss%	Total%
1								
2								
3								
4								
5								
6								
7								
8								
9								
10								

Target weed size/density:

Frame	Number of Stems	Height of tallest stem (cm)
1		
2		
3		
4		
5		
6		
7		
8		
9		
10		

Biological control agent:

10 sweeps repeated 6 times (for AP, GA, LA, CYAC & OBER) OR a 3 minute timed count repeated 6 times (for MEJA, ACMA galls & URCA galls)	
Count site	Insect (or gall) count
1	
2	
3	
4	
5	
6	

Notes:

A step-by-step guide for completing the SIMP biological control monitoring form:

General Information:

- Observer(s) – Who are you?
- Date – Today's date.
- Landowner – Who is the landowner/land manager?
- Permanent? – Is this a permanent monitoring site?
- Site name – Which site are you monitoring? This could have a specific name if it is a permanent site.
- Weed – Which target weed are you are monitoring?
- Biological control agent – Which biological control agent you are monitoring?
- Insect Stage – What is the developmental stage of the agent are you monitoring (egg, larva, nymph, pupa adult)?
- Lat/Long OR UTM – What are the GPS coordinates of the site you are monitoring? If UTM (preferred), what datum and year is your coordinate system?



Annual grass – note stems which are typically solitary or in a few stemmed tufts.

Vegetation Cover (all in %, rows add up to 100%) – All percentages are to be estimated to the nearest 5%. If there is a trace of any of the vegetation you monitoring in the frame, round up to 5%.

- Frame – Which frame number are you working on (1= 2m, 2= 4m, ..., 10 = 20m)?
- Target weed % – What is % cover of the target weed to the nearest 5%?
- Other weeds % – What is the % cover of any other weeds in the frame to the nearest 5%? Count undesirable annual grasses as weeds.
- Forb/Shrub % – What is the % cover of native forbs/shrubs in the frame to the nearest 5%?
- Grass % – What is the % cover of perennial grass to the nearest 5%?
- Bare Ground/Litter % – What is the % cover of bare ground/litter to the nearest 5%?



Perennial grass – note the multiple stem base with multiple year's growth.

Target Weed Size/Density

- Frame – Which frame number are you working on (1=2m, 2=4m, ..., 10=20m)?
- Number of stems – How many stems of the target weed are in the frame?
- Height of tallest stems (cm) – How tall is the tallest stem of the target weed in the frame (in cm)?

Biological Control Agent

- Count location – Identify 6 sites at least 5 paces away from the vegetation transect but within the same weed infestation.
- # of insects per 10 sweeps – How many insects are in your net after 10 sweeps of the surrounding vegetation? Take one step between each sweep. Repeat 5 more times (for a total of 6 sweep sites, 60 sweeps) moving at least 2 steps away from the last sweep location **(for AP, CYAC, GA, LA, & OBER).**
- # of biological control insects or galls per 3 min. count – How many biological control agents or galls do you see in a 3 minute period? Carefully approach the plants and be sure to count insects one time only. Please repeat 5 times (for a total of 6) moving at least 4 paces away from the first count location **(for, MEJA, ACMA galls & URCA galls).**